

		REVISIONS			
ZONE	REV.	DESCRIPTION	DATE	APPROVED	

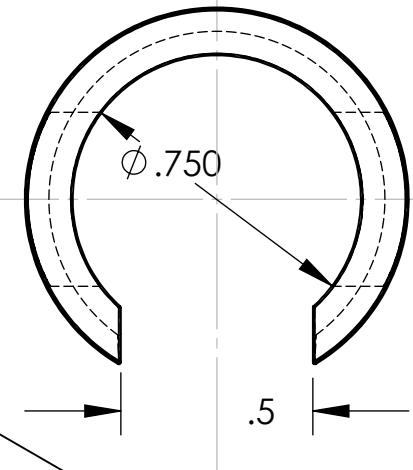

NOTE: BREAK ALL EDGES WITH 0.005 FILLET

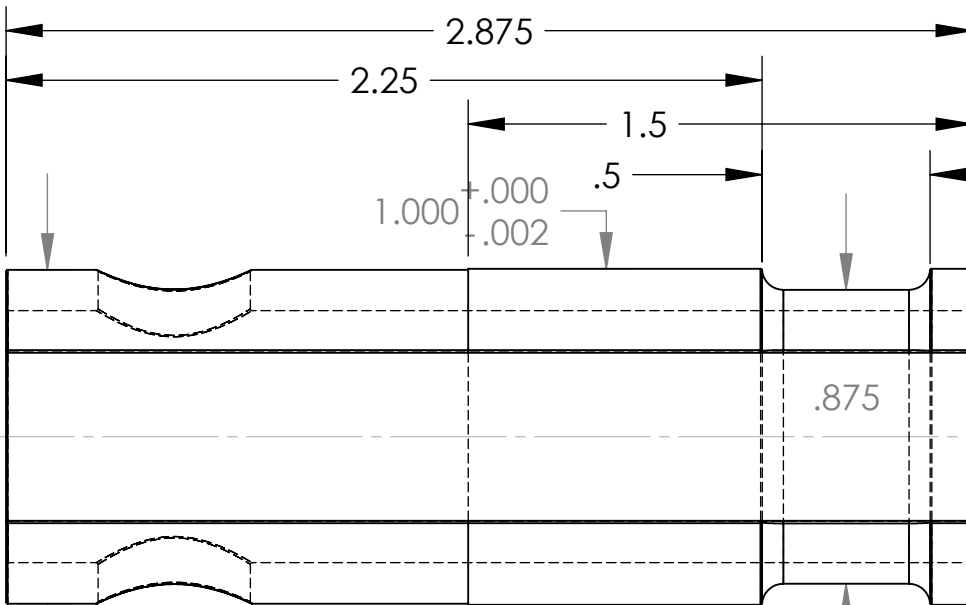
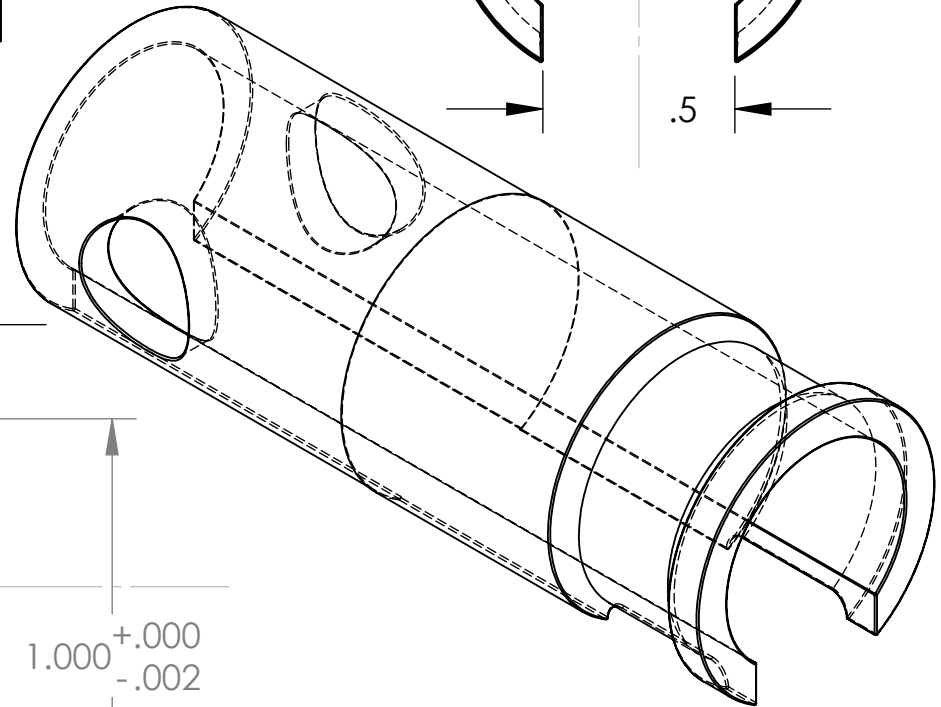

1.000 $\pm .000$ $-.002$

.993 $\pm .000$ $-.002$

R.063 X 2

PROPRIETARY AND CONFIDENTIAL
 THE INFORMATION CONTAINED IN THIS DRAWING IS THE SOLE PROPERTY OF INFINITY Aerospace. ANY REPRODUCTION IN PART OR AS A WHOLE WITHOUT THE WRITTEN PERMISSION OF INFINITY Aerospace IS PROHIBITED.

DIMENSIONS ARE IN INCHES
 TOLERANCES:
 FRACTIONAL \pm
 ANGULAR: MACH \pm BEND \pm
 TWO PLACE DECIMAL $\pm .01$
 THREE PLACE DECIMAL $\pm .005$

MATERIAL
6061-T6 Aluminum

FINISH --

	NAME	DATE
DRAWN	JDN	04/14/02
CHECKED		
ENG APPR.		
MFG APPR.		
Q.A.		

COMMENTS:

INFINITY Aerospace

Long Custom .750 ID
 Stick Grip Spacer

NEXT ASSY	USED ON
APPLICATION	DO NOT SCALE DRAWING

SIZE	DWG. NO.	REV.
A		
SCALE:2:1	WEIGHT:	SHEET 1 OF 1